

# Workshop on Modern Evaporative Cooling Technologies

Residential Overview  
July 10, 2007

Larry Kinney  
Synertech  
Systems Corp

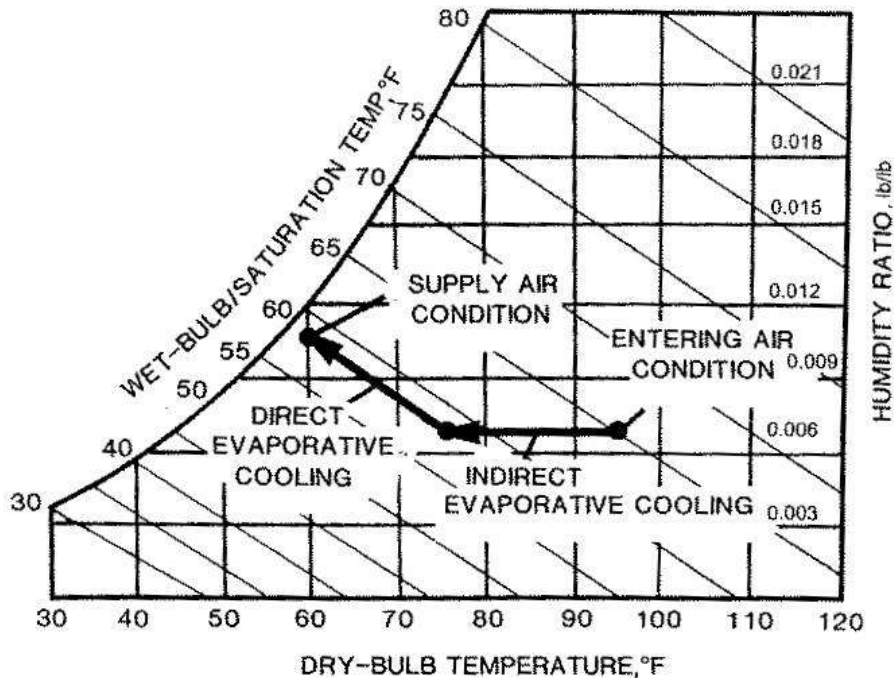
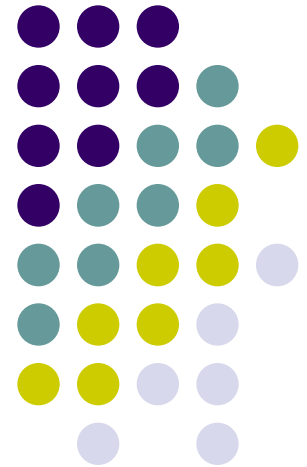

# There's a new breed of evaporative coolers

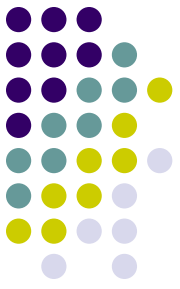

- They are no longer your basic swamp cooler; more efficient, installed in attics or on sidewalls, not necessarily on roof tops
- Can provide many years of trouble-free service; media lifetimes 5 to 10 times greater than old-style excelsior
- Easier on the grid than conventional A/C by a factor of 4 or more; similar kWh savings
- Greater comfort, greater control, much less water use

# Efficient media makes a big difference

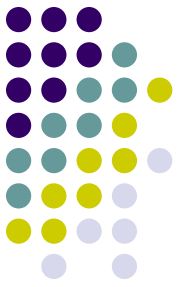

- High coefficient of heat transfer
- Water dripping across face performs cooling **and** cleaning function
- Residue ends up in sump
- Greater thickness yields greater efficiency, with greater pressure drop
- Thus, low fan speed optimizes efficiency

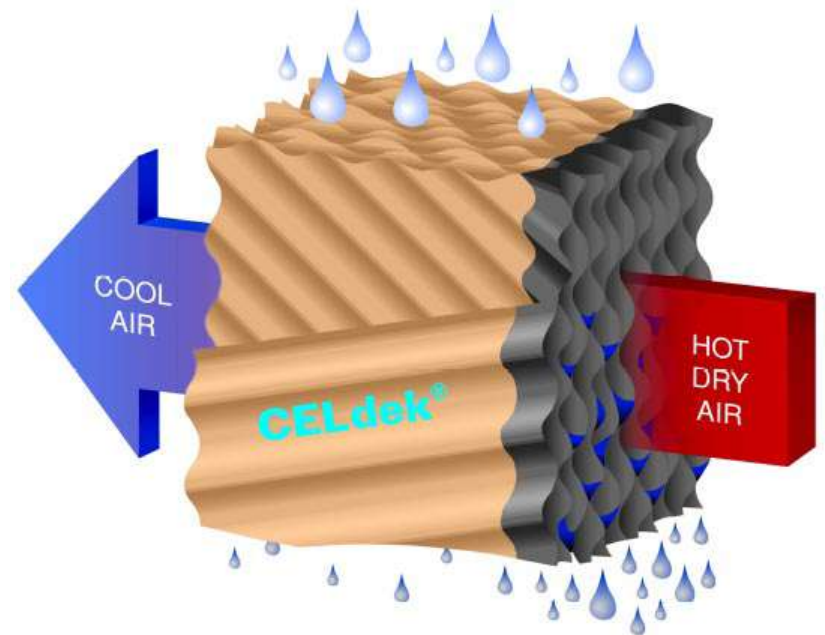

# Dry and wet bulb temperatures



- “Dry bulb” temperature is the temperature of air measured with a thermometer whose sensing element is dry. The weather channel talks dry bulb.
- If a thermometer’s sensing element is surrounded by a wet wick over which air is blown, the sensor is evaporatively cooled to its “wet bulb” temperature.
- When the relative humidity is at 100%, there is no difference between dry and wet bulb temperatures. But, as the relative humidity of the air drops, so does the wet bulb temperature with respect to dry bulb temperature.



# How much cooling?

The cooling effect depends on the temperature difference between dry and wet bulb temperatures, the pathway and velocity of the air, and the quality and condition of the media.

# 1% Wet bulb temps in the US. 70°F or below works for most people

(Source: Roy Otterbein)

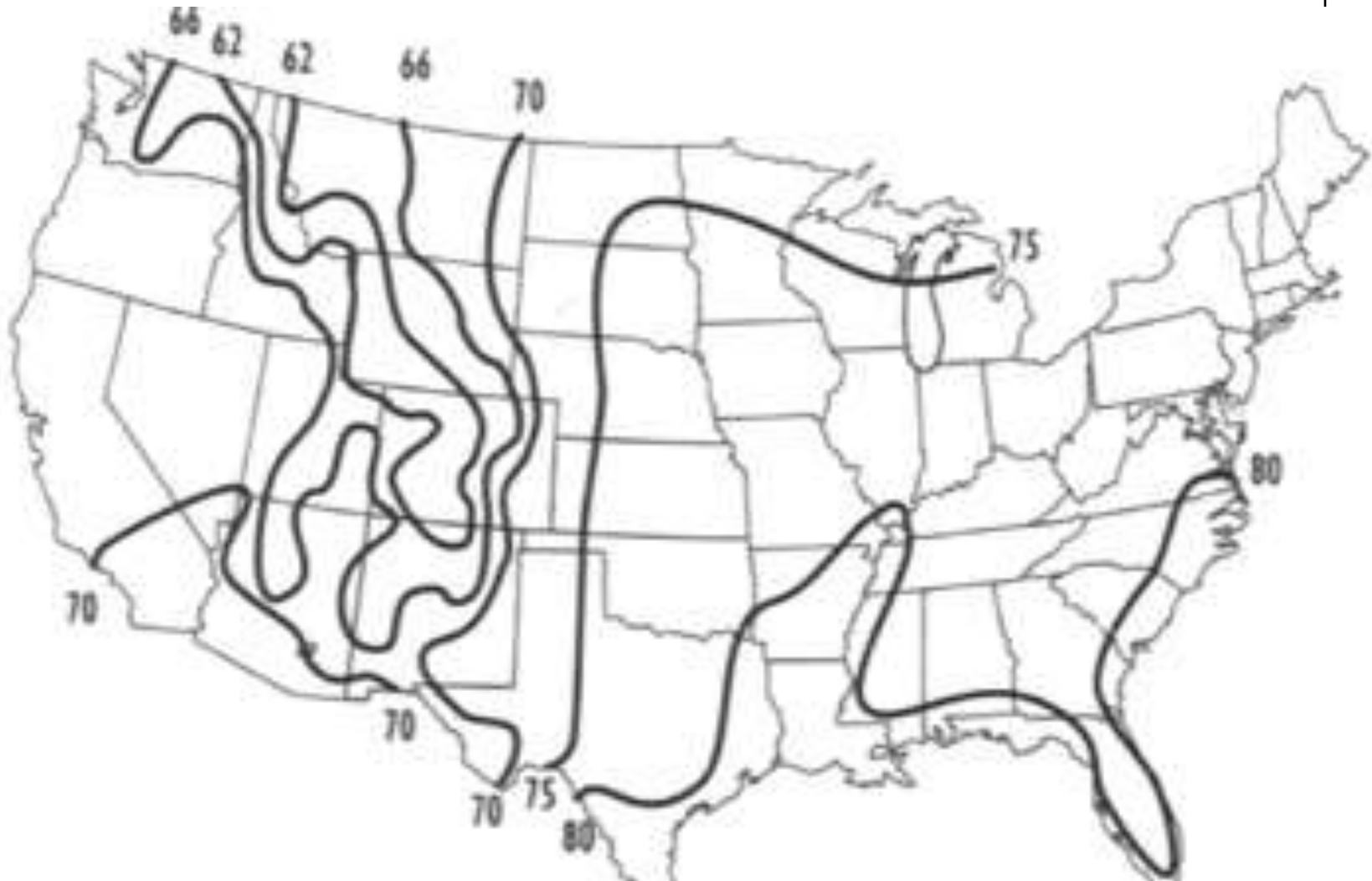

# Direct and indirect

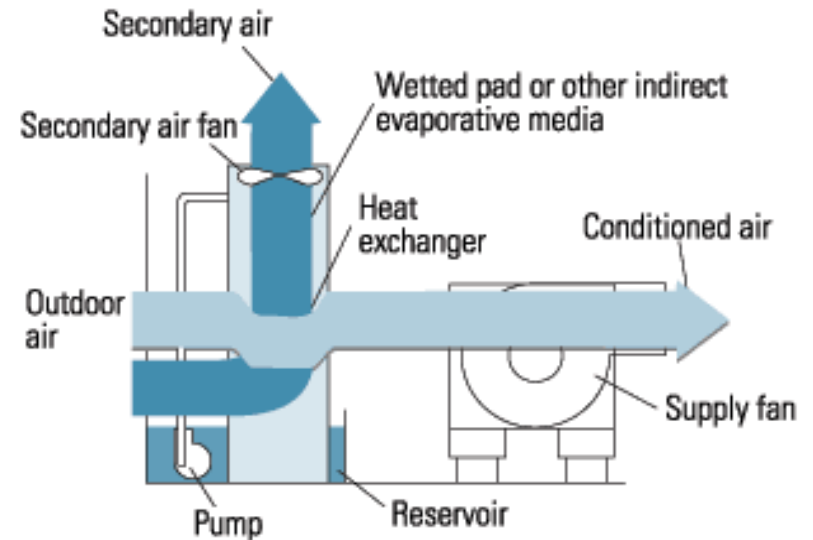
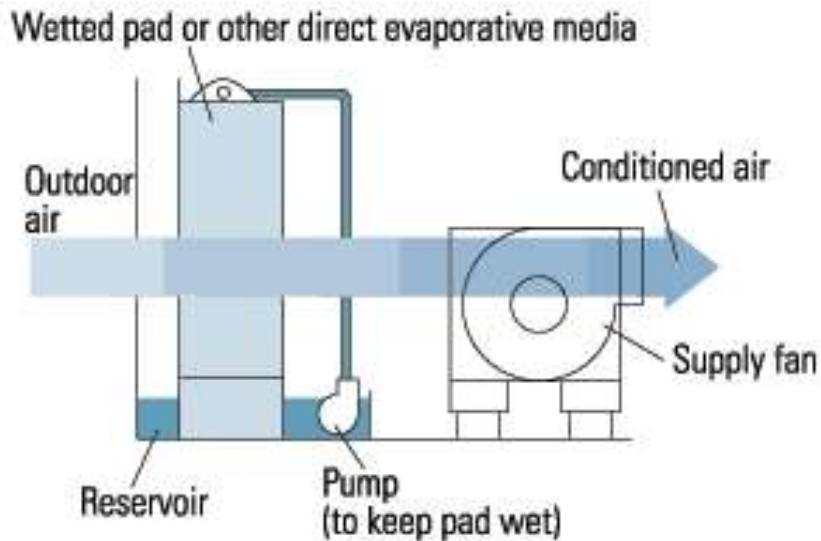

# Delivery temps (°F) at 99% wet bulb (it's hotter only 1% of the summer)



City	Dry bulb ambient temp	Wet bulb ambient temp	Temp delivered @ 85% effectiveness	Temp delivered @ 105% effectiveness
Albuquerque	93	60	65	58
Denver	90	59	64	57
Las Vegas	106	66	72	64
Phoenix	108	70	76	68

**Annual energy savings: 1800 ft<sup>2</sup>, HERS 89, EER 11  
DX A/C vs evap cooler @ 100% effectiveness  
(Energy 10 simulation, current OASys system  
performance data, EER of 77)**



City	Conventional DX (kWh/yr)	Evap cooler (kWh/yr)	Savings (kWh/yr)
Albuquerque	2,487	354	2,133
Denver	1,935	276	1,659
Las Vegas	4,722	673	4,049
Phoenix	6,043	861	5,182

# Water use in electric power generation



- Thermal power plants use about 0.47 gal/kWh generated in the US
- Conservative number of the SW (coal country) is 0.5 gal/kWh
- Hydro is 18 gal/kWh!
- P. Torcellini, N. Long, and R. Judkoff. NREL/CP-550-35190. November 2003. “Consumptive Water Use for U.S. Power Production.” Available electronically at <http://www.nrel.gov/docs/fy04osti/35190.pdf>

# Water consequences of evaporative cooling (gallons/yr)

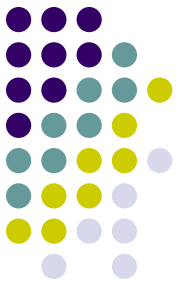

City	Source DX A/C	Source Evap	Source Save	Evap @ Site	% ave HH use	Net Evap
Alb	1,244	177	1,067	3,699	2.7%	2,633
Den	968	138	830	2,878	1.8%	2,049
Vegas	2,361	336	2,025	7,024	2.7%	4,999
Phoen	3,022	430	2,592	8,989	5.3%	6,398

# Evap cooler site water use more than made up for by either a low-flow showerhead or a low water use toilet

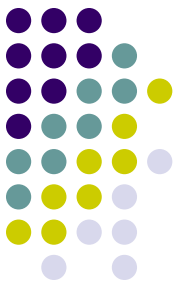

- Assumptions: 2.0 gpm shower head replaces 3.5 gpm shower head; 3 six minute showers per day
- 1.5 gallon per flush toilet replaces 4.0 gallon per flush toilet; 10 flushes per day

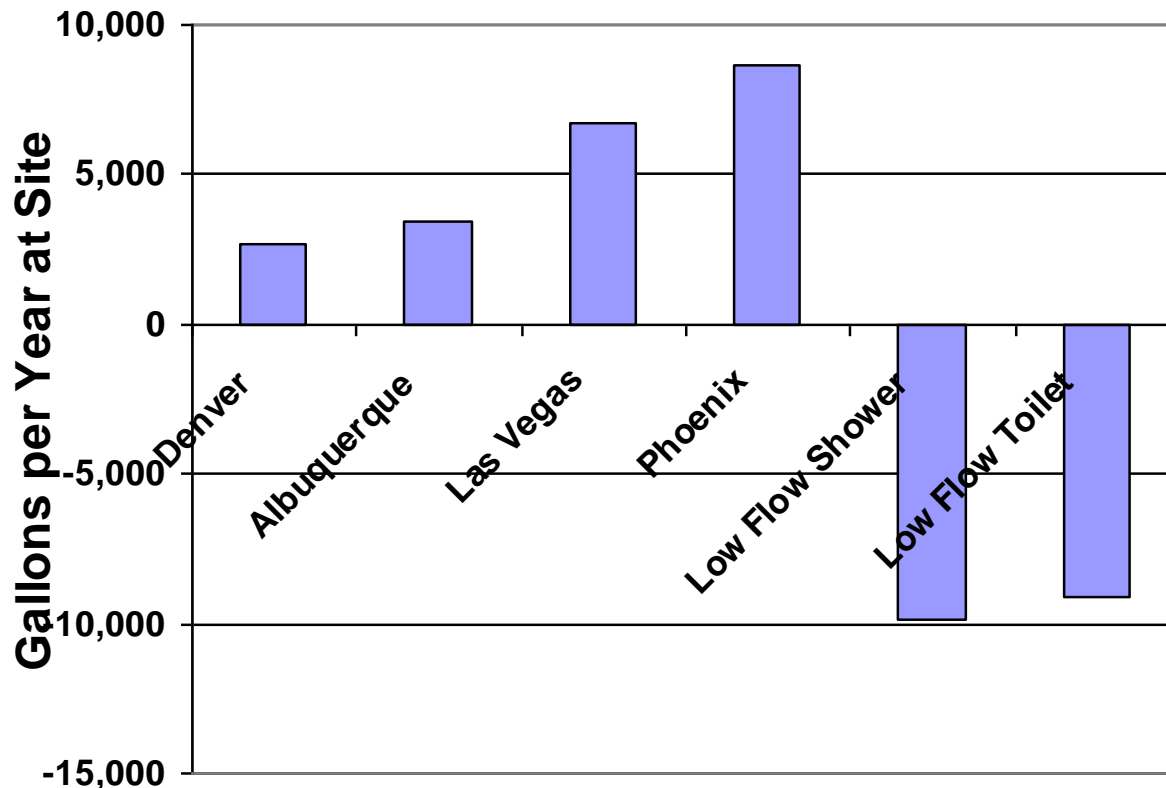

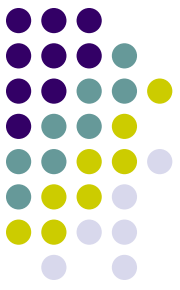

# Conclusions

- Energy savings from the best evaporative coolers average 86% in the Southwest; demand savings similar; paybacks usually instantaneous versus conventional DX.
- Water use is quite modest; most of it is made up for at the source.
- This assumes an efficient home; more wasteful homes will yield better absolute savings.
- Demand of conventional A/C will lead to new power stations.
- Evaporative cooling an elegant, straightforward solution.

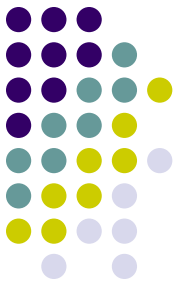

# New Coolerado cooler

- Arvada firm with indirect evap technology, new thermodynamic cycle
- Adds no moisture to air stream
- Model R600 delivers 1500 cfm air at 2°F above wet bulb
- May be ducted or not
- Can use a portion of return air since it is dry



# Performance in Boulder area for home modeled above



- 5.4 tons of cooling (64,800 Btu/hr) with 1.2 kW (4100 Btu/hr) input
- 15.8 COP, 54 EER
- Uses 12 gallons per hour of water
- To deliver cooling for the season, only 330 cooling hours, 400 kWh of electricity, 3960 gallons of water (a 3.5 gpm shower uses that much in two months)
- Annual cost for cooling home: \$40 for electricity, \$7.33 for water = \$47.33

# Coolerado hybrid (see [www.coolerado.com](http://www.coolerado.com))

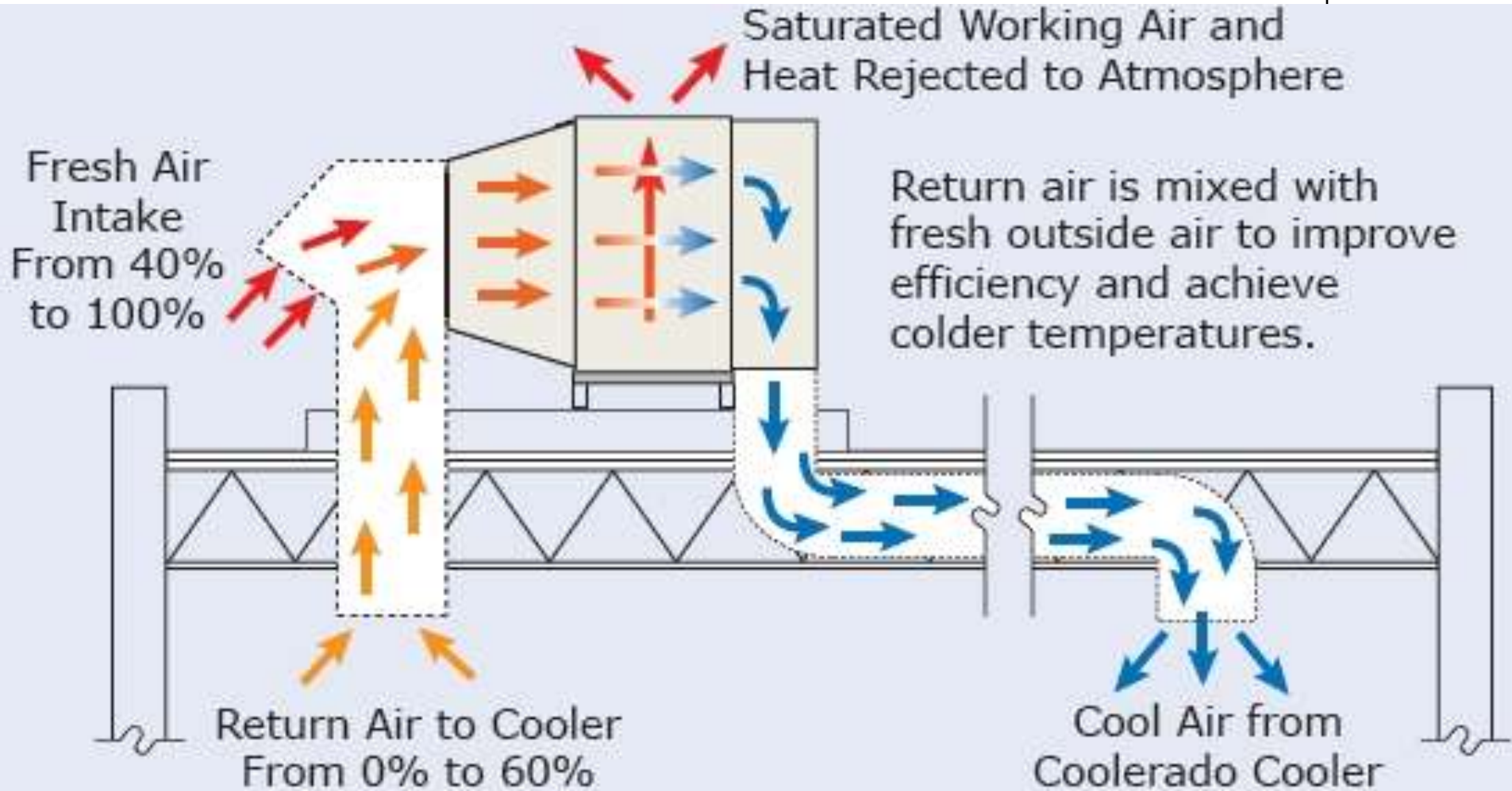
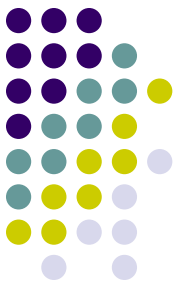

# New model of OASys available



# OASys indirect/direct has excellent performance, elegantly-simple design

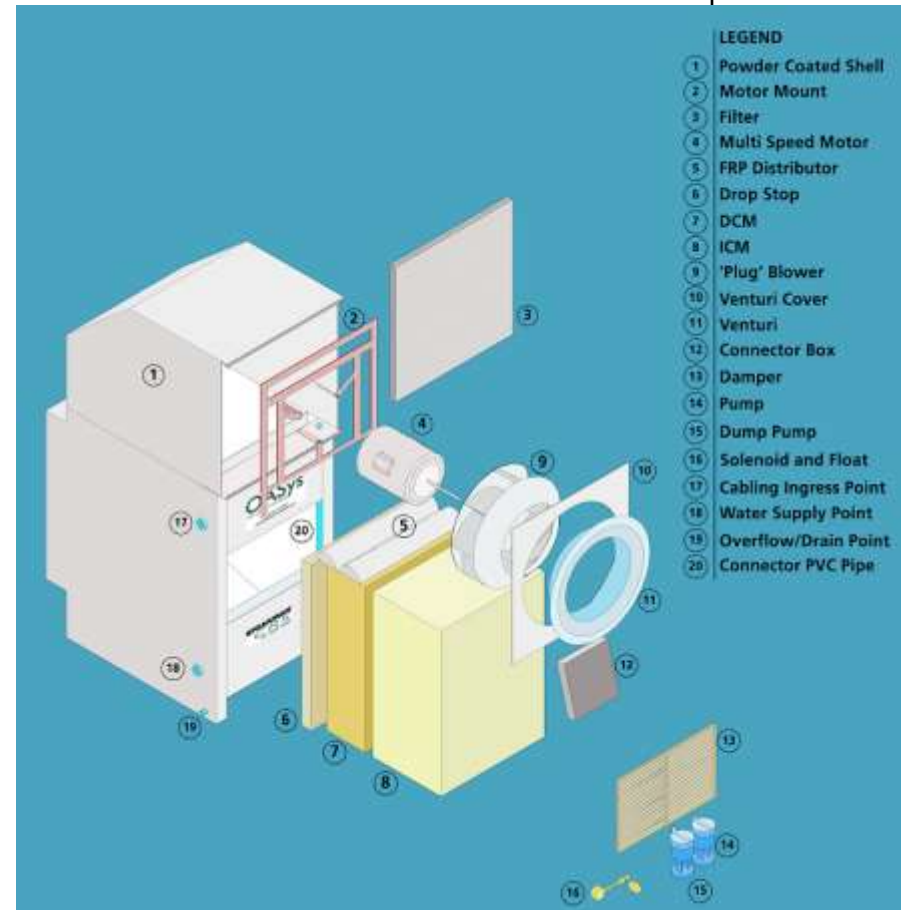
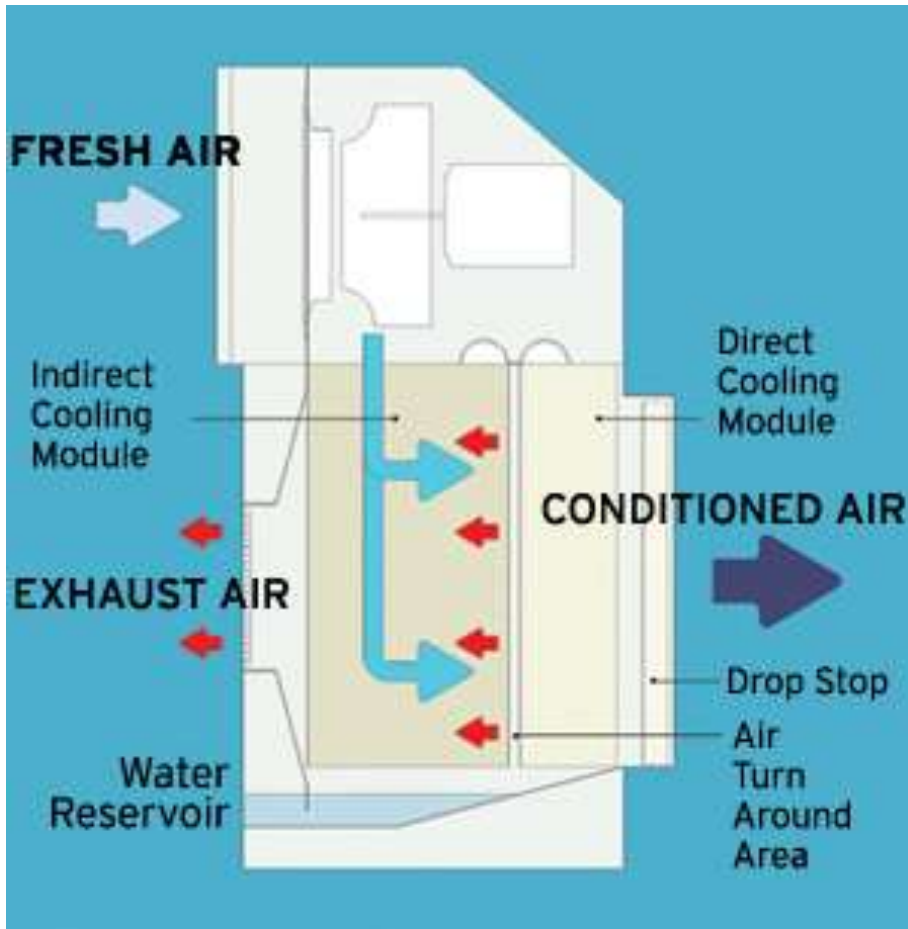
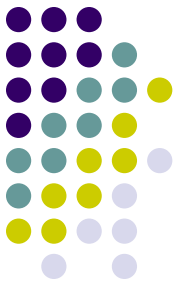

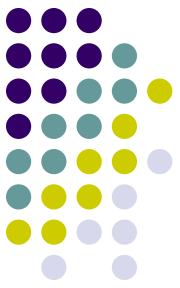

# Adobe's new through-the-wall cooler

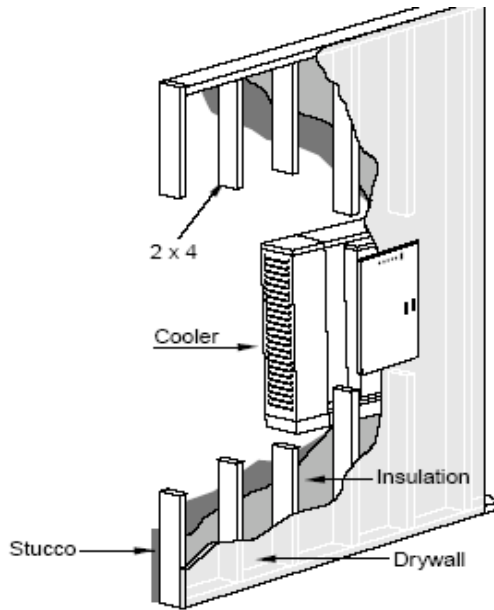

- Simple design and installation, mounts in wall
- Works with new or retrofit; aesthetic appeal
- Good efficiency for a direct evaporative cooler

# Through-the-wall is an easy installation

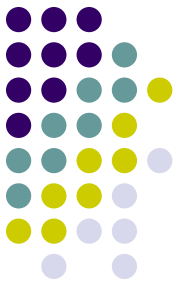

- It's best to keep evaporative coolers in the shade.
- Be sure to use with batch water ("Clean Machine") not continuous bleed.
- Simple connection to water source akin to frig auto ice maker.
- Water use nicely matched to needs of the garden.



# Remote control for Slim Wall

- Makes it easier to control the cooler; ideal for elderly and handicapped
- Simple operation, nothing complicated
- Controls all functions save for maintenance
- Included with Adobe unit at no additional cost
- N.B. bottom buttons: “high vent and low vent”



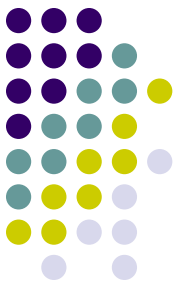

# Thermostat

- Colorado is blessed with high diurnal temperature swings; it gets chilly on most nights.
- Napping a bit after dinner while leaving the cooler on can cause serious chilliness.
- Simple thermostat solves problem gracefully.
- Wireless install takes two minutes, must have line-of-sight to cooler.



# What's needed on the hardware side?

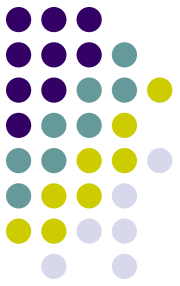

- We need to make annual maintenance more efficient, lower the risk of freezing.
- We need to enhance the performance of up ducts.
- We need to develop simpler, super-efficient coolers with smarter electronic controls.
- We need to explore systems that separate the media from the fan.

# Label

## Cooling Season:

- #1.Remove winter cover.
- #2.Screw in the drain plug to keep water from leaking out of the unit.
- #3.Reconnect any water lines that were disconnected during winter months.
- #4.Turn saddle valve counter clockwise two full rotations for water flow.
- #5Plug in the unit.
- #6Turn the unit on.

## Heating season:

- #1.Turn off the unit.
- #2.Disconnect the power source.
- #3.Turn the saddle valve clockwise until it stops.
- #4.Disconnect the water line at the lowest part of the connection.
- #5.Remove the drain plug to drain all the water from the unit.
- #6.Install the winter cover.

Saddle →  
valve



- SunPower installs many of these coolers in weatherization client homes, leaves this label in a conspicuous place.
- Also brief the clients; this is back up.

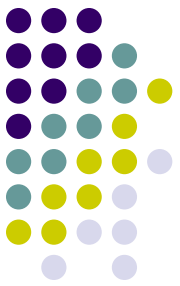

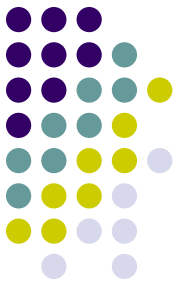

# Maintenance issue

- No matter how hard we try, there will always be the risk of freezing water lines.
- The bane of the evaporative cooler industry.
- It would be nice to be able to push a button and cut off water at the source and drain the supply line to the cooler—then push it again and be able to operate the unit.
- An advantage to all evaporative cooler users, especially elderly and handicapped.
- Won't eliminate the need for seasonal maintenance, but will keep lines from freezing and causing real problems.

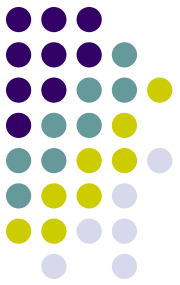

# Conceptual design

- Mounted on the cooler side of a saddle valve, the water source
- Tube from valve to cooler uphill all the way
- Ball valve with two positions: top shows summer operation, bottom winter
- Operated by a small gear motor so no power draw except when valve actuated

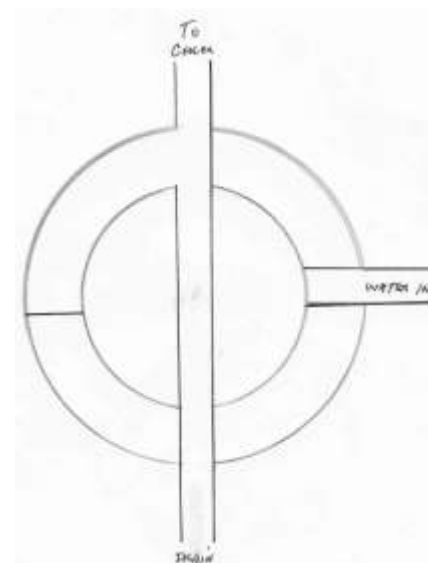
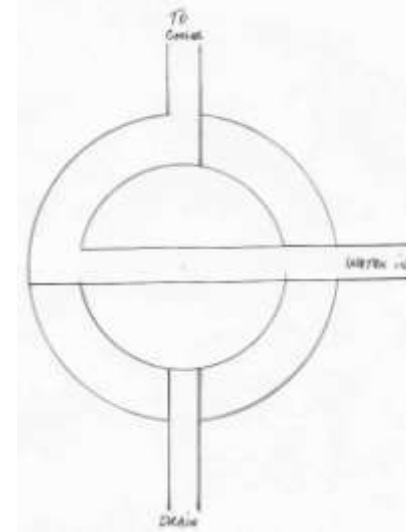

# Simple switch-actuating motor

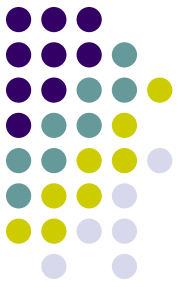

# Up Ducts

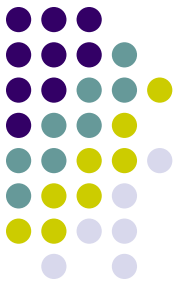

- When evaporative coolers supply cool air to a home, they also pressurize the home.
- If windows are open, cool air flows to these openings in the conditioned envelope.
- However, if “up ducts,” a kind of back-draft damper, are installed in the attic floor, exhaust air flows through them into the attic and outside through existing attic vents.
- This cools the home and lowers attic temperatures without the need for opening windows.
- The result is better security in the home and potentially good cooling distribution.

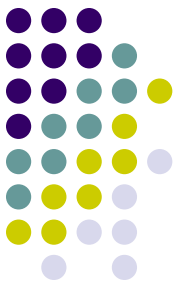

# The problem

- Up ducts currently available in the market place are flimsy.
- They are also without insulation and tend to leak.
- The spring mechanism puts maximal force to open them even without pressure differences.
- Accordingly, they tend to leak all of the time.
- This is a real energy problem when the cooler is off (like during the heating season).



Here's the result of an experiment made of polyisocyanurate, with angles crudely cut using a table saw with a plywood blade



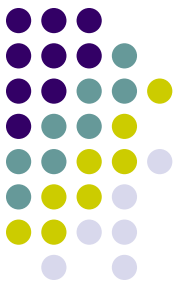

# Weights and balances

- The beaded chain is very flexible; it constrains the lid from opening  $>85$  degrees from horizontal.
- The weight slides on the chain quite easily.
- In the fully-down position, the vector pulling down the lid is maximal; when fully up, the weight has virtually no effect





# Action

- The action of the weight allows for the lid to be shut except when there's substantial pressure to open it.
- It's sealed until needed.
- Yet it should be easy for the evaporative cooler's blower to keep a number of these up ducts fully open.

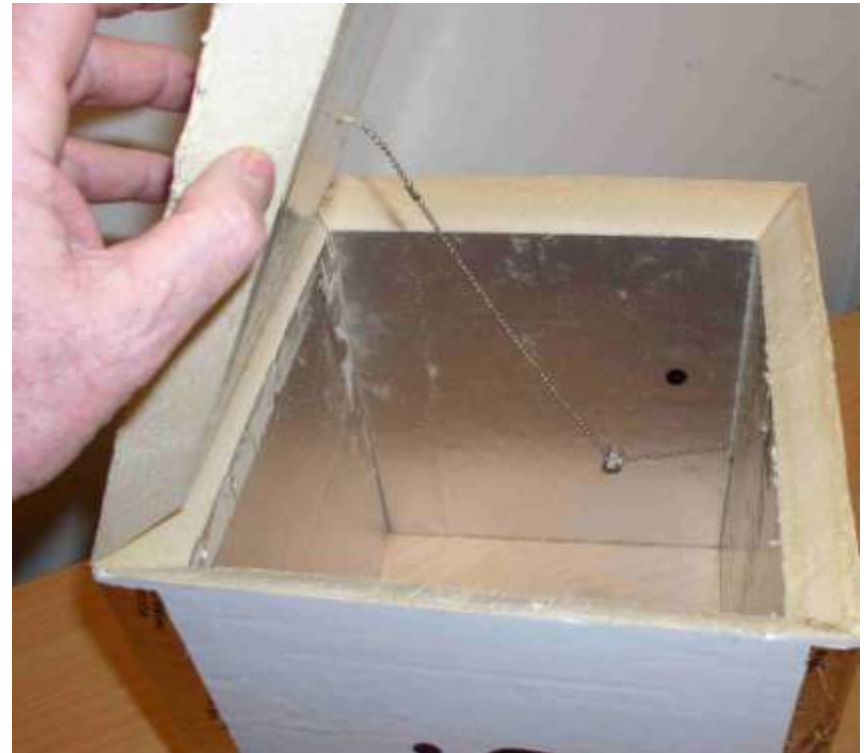

# Instead of transverse grills, Rob deKieffer has designed nifty ways of allowing air movement above interior door ways

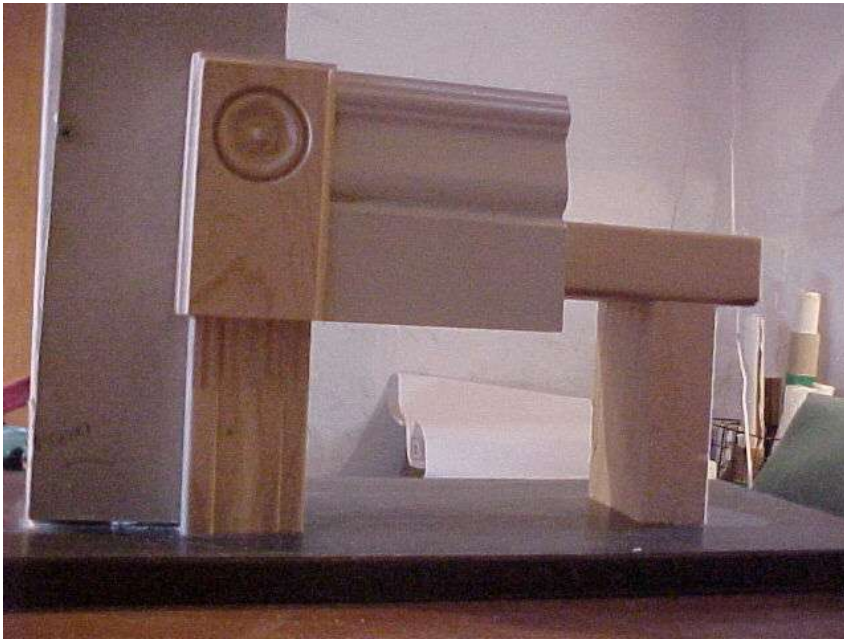

# Evaporative coolers: separating media from the fan

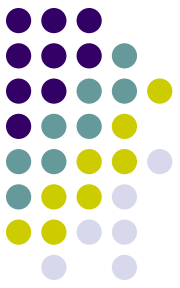

- Takes advantage of existing fans, whole house or window.
- Allows for slim through-the-wall cooling element.
- Inexpensive.
- Retrofit or new.
- Conceptually akin to evap coolers used in greenhouses

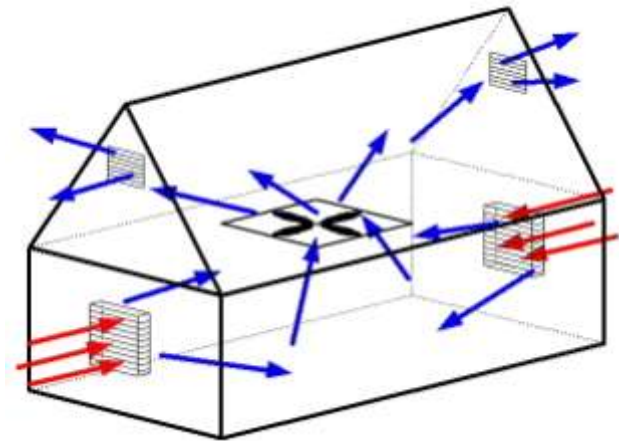
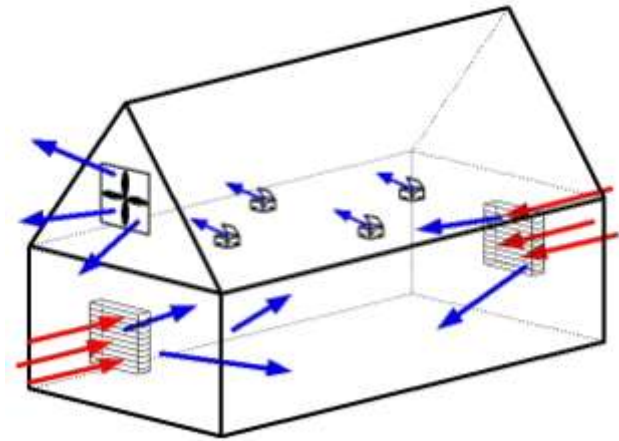

# Evaporative cooler flexibility



- Case shown envisions a window fan and one or more wall or window-installed evaporative media.
- Simple louvered grill on inside directs cool air.
- Outside insulating shutters are key to thermal performance during off cycle and provide nice aesthetics.

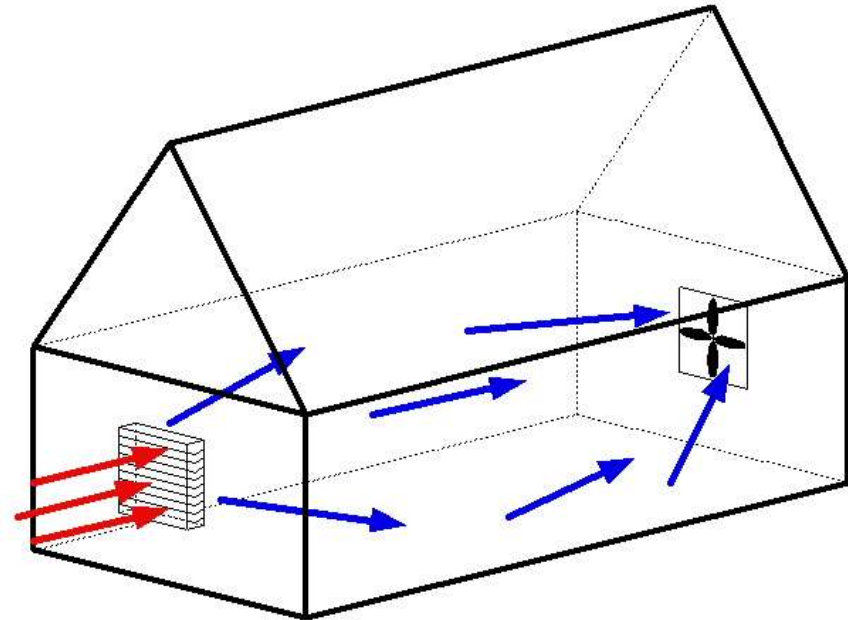

**Europeans have known for centuries that shutters make sense; an insulating shutter can also save Euros in Europe and \$ in the US**

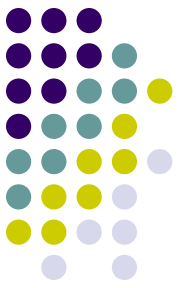

**Installation on vintage country home.  
(Imagine an evaporative cooler behind  
the shutter on the left.)**



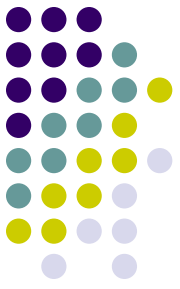

# Smart controls

- Controls need to be developed that not only vary fan speeds and control water cleaning cycles, but also monitor efficiency performance to signal the need for maintenance.
- Most important, there's a need to *think* of modern evaporative coolers as systems that should be thoroughly integrated into energy-efficient structures.

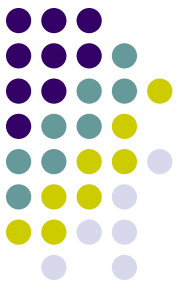

## There's plenty left to do in policy and marketing

- On the policy side, since evaporative coolers are well matched to Colorado where population growth is high, utility and government policies that promote evaporative coolers instead of conventional cooling will delay building more generating plants and associated distribution facilities.
- We must change the market! (Supplying a high-quality, low-flow shower head for free with a modern evaporative cooler could be the basis of a powerful advertisement campaign; “this simple shower head more than makes up for annual cooler water use!”) \$2.07 for this model, 1.5 gpm works well!



# Questions? Answers? Feedback?

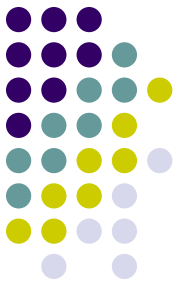

Larry Kinney

Synertech Systems Corp

1335 Deer Trail Road

Boulder, CO 80302

303-449-7941 (V)

303-579-1439 (C)

LarryK@SynertechSystemsCorp.com

[www.SynertechSystemsCorp.com](http://www.SynertechSystemsCorp.com)